



SOUND HANDBOOK

*Hints and advices for car sound builders using
DLS amplifiers and speakers*

CONTENTS:

Page	
1	Introduction
2 - 3	Formulas and facts
4 - 5	Amplifier facts
6 - 8	Passive crossover filters
9	Cabling
10 - 13	Installation
14 - 20	Building speaker boxes
21	Enclosure examples
32	Some useful tables

DLS Svenska AB
P.O. Box 13029, SE-402 51 Göteborg, Sweden
Tel. +46 31 84 00 60
Fax +46 31 84 40 21
E-mail: info@dls.se
www.dls.se

INTRODUCTION

We have made this handbook as a small help for those who want to do a first class car sound installation.

This book advises the reader in matters concerning amplifier and speaker installation and wiring, passive crossovers, cable choice and different bass box constructions. Information about DLS products can also be found on our Internet WEB-site www.dls.se

DLS SOUND PHILOSOPHY

DLS sound philosophy is based upon providing equipment that will accurately and faithfully reproduce all kinds of music without distortion and colouration. The sound reproduction must be natural, the soundstage well imaged and stable even when the tweeters are mounted apart from the bass/midrange elements.

If you close your eyes the sound should be as close as possible to the real. You should be able to experience the sound as it is in the concert hall or on a rock concert. Every instrument and singer should be on it's correct place on the stage. To achieve this you need a good front stage image and to do such an installation is not easy. DLS amplifiers and speaker systems will help you to achieve a sound as good as possible, but you also have to do a correct installation if you want a perfect result. This book will give you hints about doing a good installation.

DLS lay a great job in developing and refining the different products in order to give the market the best Car-Hi-Fi products possible to the worlds most demanding listeners.

DLS AMPLIFIER PHILOSOPHY

A wellknown french sound philosopher, Jean Hiraga, said regarding home Hi-Fi: A good sound starts in the mains plug and then through the AC/DC-converter, which must be oversized.

The same is valid for Car Hi-Fi, the amplifier must at all occasions have enough power to make a good job. Remember to use well oversized cables from the battery to the amplifier. It is also essential that the DC/DC-converter is well oversized to make it distribute enough power to the amplifiers final stage when it's needed, otherwise both the dynamics and the good sound will be lost. The amplifier will sound "tired" and the sound will be strained. The bass will lack the real "bass-kick" and the treble becomes sharp instead of soft and airy.

The built-in amplifiers in most CD:s and stereo cassette players can't stand up to these demands. To achieve a good sound it's necessary to install an external high quality amplifier.

AMPLIFIER CLASSES

Depending upon the construction, amplifiers are divided into different classes, there are class A, AB, B or C. The characteristic mark for a class A amplifier is the lack of switching noise distortion, which the other types have. The class A amplifier also has a higher idle current, but instead it creates a much better resolution and dynamics. For home use the class A amplifiers are not very common, many people think they are only for sound connoisseurs and Hi-Fi enthusiasts. Powers from 2x15 up to 2x50 Watts are common on these types, no high power, but instead real good AC/DC-converters with reliable power resources.

The most common amplifier type is class AB.

Now you can also find class "D" amplifiers. Class D amplifiers process the signal in a digital way and this gives the amplifier a high efficiency. A normal class AB amplifier has an efficiency of around 50%. This means that a 500 watt amplifier will take up to a 1000 watts from the battery and 50% of it will be transformed to heat. The power transistors must work very hard and will get very hot. A class D amplifier has an efficiency of 80-90%. and the heat dissipation is much lower. The power consumption is also much lower.

The disadvantage of a class D amplifier is the higher distortion and it is also difficult to make it work over the entire audible frequency range. Class D amplifiers are normally used only as subwoofer amplifiers with limited frequency range.

DLS AMPLIFIERS 2007:

DLS amplifiers in ULTIMATE series work in class AB. In order to minimize the transient distortion the final stage uses accurately matched transistor

These are the ULTIMATE-series models:

- A2 - The Mid Stereo
- A3 - The Twin Mono
- A4 - The Big Four
- A5 - The Big Five
- A6 - The Mono Amp
- A7 - The Big Five
- TA2 - Tube amplifier

The Reference amplifiers are also working in class AB.

These are the Reference-series models:

RA10, RA20, RA25, RA30, RA40 & RA50.

These are the Performance-series models:

CA12, CA22, CA23, CA31, CA41, CA51, CAD11 & CAD15.

CAT31-24 is a CA31 for 24 Volt use.

FORMULAS

It's easier to understand some parts in this book if you know some of the formulas on this page. They are also useful at many other occasions.

OHMS LAW:

R = resistance in ohm, U = voltage in Volt
I = current in Ampere, P = power in Watt

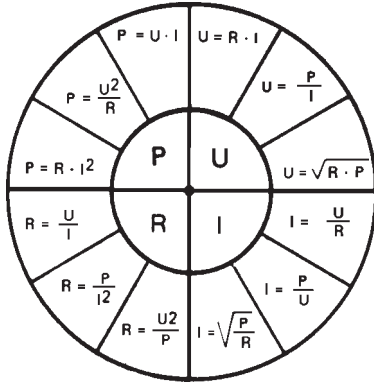

GEOMETRY:

Circle:

r = radius O = periphery
d = diameter A = area

$$\text{Radius (r)} = \frac{O}{2\pi} \qquad \text{Diameter (d)} = \frac{O}{\pi}$$

$$\text{Periphery (O)} = 2\pi \times r \qquad \text{Area (A)} = \pi \times r^2$$

Box volumes (V):

When calculating the volume of a box you simply multiply the width (W) x height (H) x depth (D). Use measures in dm and you will get the answer in liters.

A trapezoid box is calculated as below:

$$V = \text{width (W)} \times \text{height (H)} \times \frac{\text{upper depth} + \text{lower depth}}{2}$$

To get the net volume use the inner measures of the box.

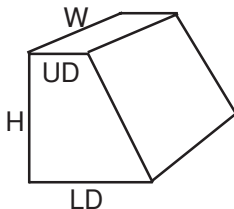

Volume (V) of a pipe:

D = depth (length) r = radius

$$V = r^2 \times 3,14 \times D$$

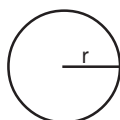

Use measures in dm and you will get the answer in liters.

MEASURE CONVERSION

The following relation between some units are useful to know of.

- 1 yard (yd) = 3 ft = 36 in = 0,9144 m
- 1 foot (ft) = 0,3048 m
- 1 inch (in) = 2,54 cm
- 1 square yard (yd²) = 9 ft² = 1296 in² = 0,8361 m²
- 1 square foot (ft²) = 144 in² = 9,290 dm²
- 1 square inch (in²) = 6,452 cm²
- 1 cubic yard (yd³) = 27 ft³ = 0,7646 m³
- 1 cubic foot (ft³) = 1728 in³ = 28,32 dm³
- 1 cubic inch (in³) = 16,39 cm³
- 1 pound (lb) = 16 oz = 0,4536 kg
- 1 ounce (oz) = 28,35 gram

CONVERSION GAUGE - mm²

Gauge (ga) is an American measure for cable areas, also called AWG (American Wire Gauge).

- | | |
|----------------------------|-------------------------------|
| 1 AWG = 42 mm ² | 9 AWG = 6,8 mm ² |
| 2 AWG = 33 mm ² | 10 AWG = 5,3 mm ² |
| 3 AWG = 27 mm ² | 11 AWG = 4,2 mm ² |
| 4 AWG = 21 mm ² | 12 AWG = 3 mm ² |
| 5 AWG = 16 mm ² | 13 AWG = 2,7 mm ² |
| 6 AWG = 13 mm ² | 14 AWG = 2 mm ² |
| 7 AWG = 10 mm ² | 15 AWG = 1,65 mm ² |
| 8 AWG = 8 mm ² | 16 AWG = 1,3 mm ² |

SPEAKER TERMS

It's useful to know what the most common speaker data terms stands for.

Fs = speaker resonant frequency in Hz

Fc = box resonant frequency in Hz

F3 = approximative lower frequency for vented boxes in Hz. Often called F-3 dB point = the point where the power is half.

Qes = the speakers electrical Q-value

Qms = the speakers mechanical Q-value

Qts = the speakers total Q-value

Vas = Equivalent air volume. The air volume having the same acoustic compliance as the speaker suspension.

X-max = voice coil length - 2 x thickness of the inner pole plate.

Sd = the speakers effective cone area

Vb = net volume of the box

SPL = sound pressure level in dB

Sens. = speaker sensitivity in dB at 1Watt / 1 mtr

Re = speaker DC resistance in ohms

Mms (Mmd) = moving mass

Le (Lbm) = Voice coil inductance

RMS = AC average power value

BL = The flux density factor in the magnetic gap in the speaker * the wire length of the voice coil

DECIBEL - dB

dB is a unit used to describe a relation. It's used to describe an amplification as well as an attenuation. At an attenuation a minus sign is put before the figure.

An amplification is the relation between the input and the output signal. In can be valid for voltage, current or power.

When used for power amplification you must remember that current x voltage = power. This means that the relation becomes larger, see the table below.

Examples of fixed dB relations:

For voltage and current:

dB	Amplification
0 dB	1 time
1 dB	1,1 times
3 dB	1,4 times
6 dB	2 times (double)
10 dB	3,16 times
20 dB	10 times

The amplification increases logarithmic.

For power:

dB	Amplification
0 dB	1 time
3 dB	2 times
6 dB	4 times
10 dB	10 times
20 dB	100 times

An attenuation of -6 dB is a half for voltage and current and a quarter when talking about power.

CONNECTION OF CAPACITORS

Capacitors acts in the opposite way as resistors when connected in series or parallel.

IN PARALLEL:

The total capacitance when connecting capacitors in parallel is the sum of each capacitor.

$$C_{tot} = C1 + C2 + C3 + C4 \text{ etc.}$$

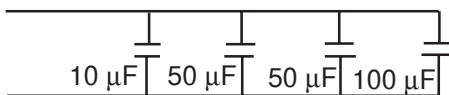

$$C_{tot} = 10 + 50 + 50 + 100 = 210 \mu F$$

- 1 μF = 0,000001 Farad (10⁻⁶)
- 1 nF = 0,000000001 Farad (10⁻⁹)
- 1 pF = 0,000000000001 Farad (10⁻¹²)

CONNECTING RESISTORS

The formualas below is valid when connecting resistors and inductances in series or in parallel. It can also be used for speakers.

IN SERIES:

The total resistance is equal to the sum of all resistors in the connection.

$$R_{tot} = R1 + R2 + R3 + R4 \text{ etc.}$$

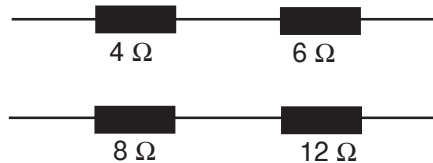

$$R_{tot} = 4 + 6 + 8 + 12 = 30 \Omega$$

IN PARALLEL:

When connecting in parallel the total resistance always becomes lower, it is always lower than the lowest resistor value in the connection.

$$\text{Formula: } \frac{1}{R} = \frac{1}{R1} + \frac{1}{R2} + \frac{1}{R3} + \frac{1}{R4}$$

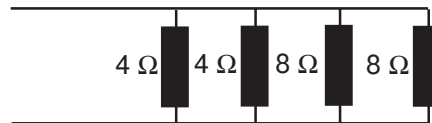

$$\frac{1}{R} = \frac{1}{4} + \frac{1}{4} + \frac{1}{8} + \frac{1}{8} \quad R = 1,33 \Omega$$

When connecting only two resistors in parallel you can use the formula below.

$$R = \frac{R1 \times R2}{R1 + R2} \quad \text{Ex. } \frac{4 \times 8}{4 + 8} = \frac{32}{12} = 2,66 \Omega$$

IN SERIES:

When connecting capacitors in series you calculate in the same way as for resistors connected in parallel.

$$\text{Formula: } \frac{1}{C} = \frac{1}{C1} + \frac{1}{C2} + \frac{1}{C3} + \frac{1}{C4}$$

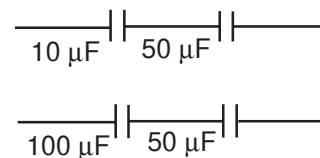

$$\frac{1}{C} = \frac{1}{10} + \frac{1}{50} + \frac{1}{50} + \frac{1}{100} \quad C = 6,66 \mu F$$

When connecting only two capacitors you can use the same formula as in the example with two resistors connected in parallel above.

DLS SOUND HANDBOOK - AMPLIFIER FACTS

DLS ULTIMATE AMPLIFIERS	A1	A2	A3	A4	A5	A6	A7	A8
Number of channels	2	2	2	4	3	1	5	4
Power output in 4 ohm	2x45 W	2x85 W	2x150 W	4x85 W	2x85 W	1x500 W	4x60 W	4x40W
Power output in 2 ohm	2x80 W	2x145 W	2x270 W	4x145 W	2x100 W	1x870 W	4x100W	4x80 W
Power output in 1 ohm	2x120 W	2x220 W	2x425 W	2x220 W	-	1x1200 W	-	-
Mono bridge mode 4 ohm	1x160 W	1x290 W	1x550 W	2x250 W	-	-	-	2x165W
Mono bridge mode 2 ohm	1x240 W	1x450 W	1x870 W	2x400 W	-	-	-	2x220W
Mono bridge mode 1 ohm	-	-	1x1200 W	-	-	-	-	-
Mono sub channel, nom. power 4 ohm	-	-	-	-	1x300 W	-	1x300 W	-
Mono sub channel, nom. power 2 ohm	-	-	-	-	1x500 W	-	1x440 W	-
Mono sub channel, nom. power 1 ohm	-	-	-	-	1x780 W	-	1x600 W	-
S / N ratio, A-weighted	>100 dB	>100 dB	>100 dB	>100 dB	>100 dB	>100 dB	>100 dB	>100 dB
Damping factor	>200	>200	>200	>200	>200	>200	>200	>200
Input impedance	>10 k	>10 k	>10 k	>10 k	>10 k	>10 k	>10 k	>10 k
Input sensitivity	0,2-7V	0,2-7V	0,2-7V	0,2-7V	0,2-7V	0,2-7V	0,3-7V	0,5-5V
Filter highpass	20-200 Hz	20-200 Hz	20-200 Hz	FRONT: LP: 50-125 Hz HP: 20-200/60-600 Hz	50-150 Hz	-	FRONT: 20-400Hz/1,6-8 kHz REAR: 80-400 Hz	Off/70/90 Hz
Filter lowpass	Off/70/90 Hz	50-125 Hz*	50-125 Hz* HP: 20-200 Hz	REAR: P: 45-200/90-400 Hz	40-90 Hz	50-125 Hz SUB CH: 50-125 Hz	REAR: 0,3-4 kHz/3-40 kHz	50-125 Hz
*can be switched in/out	-	-	-	-	-	-	SUBSONIC: 25 Hz	-
Subsonic filter 25 Hz/18 dB	-	-	-	-	yes	yes	no	-
Dual DC-inputs	-	-	yes	yes	-	yes	-	-
Phase shift button 0 / 180°	-	-	yes	-	-	-	-	-
Phase shift control continuous	-	-	-	-	0-180 degrees	0-180 degrees	0-180 degrees	-
Fan output terminal	-	-	yes	yes	yes	yes	yes	-
Remote sub level control	-	-	-	-	yes	yes	yes	-
POWER CONSUMPTION								
Idle	0,5 A	0,6 A	1,1 A	1,5 A	0,5 A	0,6 A	1,1 A	0,7 A
Maximum	32 A	60 A	140 A	95 A	90 A	140 A	120 A	50 A
Dimensions (mm)	205x240x73	265x240x73	410x240x73	465x240x73	410x240x73	410x240x73	605x240x73	350x240x73
Dimensions (inch)	8,07x9,45x2,87	10,43x9,45x2,87	16,15x9,45x2,87	18,30x9,45x2,87	16,15x9,45x2,87	16,15x9,45x2,87	23,82x9,45x2,87	13,78x9,45x2,87
Weight	2,8 kg (6,17 lb)	3,7 kg (8,16 lb)	6,2 kg (13,67 lb)	6,6 kg (14,55 lb)	5,9 kg (13 lb)	6,2 kg (13,67 lb)	8,1 kg (17,86 lb)	4,8 kg (10,6 lb)

DLS REFERENCE	RA20	RA25	RA30	RA40	RA50
R.M.S. Power output at 13,8 Volts, 20 Hz - 20 kHz, max 0,1% THD, all channels driven:	2 x 130 W	2 x 70 W	2 x 70 W + 1 x 265 W	4 x 75 W	4 x 70 W + 1 x 265 W
Number of channels	2	2	3	4	5
Power output in 4 ohm	2 x 130 W	2 x 70 W	2 x 70 W + 1 x 265 W	4 x 75 W	4 x 70 W + 1 x 265 W
Power output in 2 ohm	2 x 220 W	2 x 110 W	2 x 100 W + 1 x 365 W	4 x 110 W	4 x 110 W + 1 x 365 W
Power output 4 ohm bridged	1 x 440 W	1 x 220 W	-	2 x 220 W	2 x 220 W
Signal to noise ratio, A-weighted	>100 dB	>100 dB	>100 dB	>100 dB	>100 dB
Damping factor	>200	>200	>200	>200	>200
Frequency response +/- 0,5 dB	10 Hz - 50 kHz	10 Hz - 50 kHz	10 Hz - 50 kHz	10 Hz - 50 kHz	10 Hz - 50 kHz
Input impedance, low level	>10 kohms	>10 kohms	>10 kohms	>10 kohms	>10 kohm
Input impedance, high level	330 ohms	330 ohms	330 ohms	330 ohms	330 ohm
High level input with auto start	yes	yes	yes	yes	yes
Input sensitivity	0,2 - 7 V	0,2 - 7 V	0,2 - 7 V	0,2 - 7 V	0,5 - 8 V
Bass boost adjustable gain @ 40 Hz	0 - +18 dB	-	0 - +18 dB	0 - +18 dB	0 - +18 dB
Phase shift 0 - 180 degrees continuously	yes	-	yes	yes	yes
Remote bass level and phase shift	-	-	yes, on sub ch.	-	yes, on sub ch.
Filter highpass / fixed subsonic filter	20 - 150 Hz*	20 - 150 Hz*	45 - 125 Hz* / 25 Hz*	20 - 150 Hz on all ch.	see spec.
Filter lowpass	40 - 125 Hz*	-	40 - 125 Hz	40 - 125 Hz*	see spec.
*can be switched in/out	-	-	-	-	-
POWER CONSUMPTION					
Idle	0,6 A	0,6 A	0,9 A	0,9 A	1,2A
Maximum	50 A	25A	70 A	50 A	90 A
Fuses	2 x 25 A	1 x 25 A	2 x 35 A	2 x 25 A	3 x 30A
Dimensions (mm)	59 x 359 x 245	59 x 247 x 245	59 x 385 x 245	59 x 359 x 245	59 x 479 x 245 mm
Dimensions (inch)	2,33 x 14,1 x 9,65	2,33 x 9,72 x 9,65	2,33 x 15,15 x 9,65	2,33 x 14,1 x 9,65	2,33 x 18,85 x 9,65
Weight	3,8 kg / 8,4 lb	2,6 kg / 5,7 lb	4,4 kg / 9,3 lb	4 kg / 8,8 lb	5,5 kg / 12,1 lb

FILTER CONFIGURATION RA50

Ch. 1 & 2
High-pass 50 - 140 Hz*
Low-pass 250 - 700 Hz* (x 1 switch)
or 2,5 kHz - 7 kHz* (x 10 switch)

Ch. 3 & 4
High-pass 50 Hz - 140 Hz (x 1 switch)
or 250 Hz - 700 Hz (x 5 switch)
or 2,5 kHz - 7 kHz (x 50 switch)

Ch. 5
Low-pass 40 Hz - 125 Hz
Subsonic fixed 25 Hz*

*can be switched in/out

DLS REFERENCE	RA10
Number of channels	1
Amplifier class	AB
Power output in 4 ohm (0,1% THD)	1 x 300 W
Power output in 2 ohm (0,1% THD)	1 x 500 W
Power output in 1 ohm (0,1% THD)	1 x 820 W
All power ratings at 13,8 Volt	-
Signal to noise ratio, A-weighted	>100 dB
Damping factor	>200
Frequency response	10 Hz - 125 Hz
Input impedance	>10 kohms
Input impedance, high level	330 ohms
High level input with auto start	yes
Input sensitivity	0,5 - 8 V
Phase control continuous	0 - 180 degrees
Bass boost adjustable gain	0 - +18 dB
Filter subsonic, 18 dB slope	25 Hz fixed
Filter lowpass 12 dB slope	40 - 125 Hz
*can be switched in/out	-
Power consumption, idle	1,5 A
Fuse	3 x 40 A
Dimensions (mm)	59 x 359 x 245
Dimensions (inch)	2,33 x 14,1 x 9,65
Weight	5,4 kg / 11,9 lb

DLS SOUND HANDBOOK - AMPLIFIER FACTS

DLS Performance	CA 22	CA 23	CA 31	CAT 31	CA 41	CA 51
R.M.S. Power output at 13,8 Volts, 20 Hz - 20 kHz, all channels driven:						
Number of channels	2	2	3	3	4	5
Power output in 4 ohm (0,1% THD)	2 x 60 W	2 x 135 W	2 x 65 W + 1 x 170 W	2 x 75 W + 1 x 170 W	4 x 70 W	4 x 50 W + 1 x 170 W
Power output in 2 ohm (0,2% THD)	2 x 100 W	2 x 200 W	2 x 90 W + 1 x 280 W	2 x 145 W + 1 x 280 W	4 x 125 W	4 x 80 W + 1 x 285 W
Power output in 1 ohm (0,5% THD)				2 x 210 W + N/A		
Power output 4 ohm bridged	1 x 200 W	1 x 400 W	1 x 170 W	1 x 280 W	2 x 200 W	2 x 150 W
Signal to noise ratio, A-weighted	>100 dB	>100 dB	>100 dB	>90 dB	>100 dB	>100dB
Damping factor	>100	>100	>100	>100	>100	>100
Frequency response	10 Hz - 35 kHz	10 Hz - 35 kHz	10 Hz - 35 kHz	10 Hz - 35 kHz	10 Hz - 35 kHz	10 Hz - 35 kHz
Input impedance, low level	>10 kohms	>10 kohms	>10 kohms	10 Hz - 35 kHz	>10 kohms	>10 kohms
Input impedance, high level	100 ohms	100 ohms	100 ohms	100 ohms	100 ohms	100 ohms
High level input with auto start	yes	yes	yes	yes	yes	yes
Low output	yes	yes	no	no	yes	No
Input sensitivity	0,25 - 5 V	0,25 - 5 V	0,25 - 5 V	0,25 - 5 V	0,25 - 5 V	0,25 - 5 V
Grand bass adjustable frequency	-	25 Hz - 80 Hz	no	no	25 Hz - 80 Hz	no
Grand bass adjustable gain	-	0 - 18 dB	no	no	0 - 18 dB	no
Phase control continuous	no	no	0-180 degrees	0-180 degrees	no	0-180 degrees
Filter highpass / subsonic	15 - 500 Hz*	15 - 150 Hz*	15 - 150 Hz* / Yes, 25 Hz	50 - 150 Hz* / Yes, 25 Hz*	see spec.	see spec.
Filter lowpass	50 - 500 Hz*	50 - 500 Hz*	50 - 120 Hz	50 - 120 Hz, 24 dB slope	see spec.	see spec.
*can be switched in/out				NOTE! For 24 volt use		
POWER CONSUMPTION						
Idle / max	0,5 A / 25 A	0,7 A / 60 A	1,0 A / 60 A	0,7 A / 40 A	0,7 A / 60 A	1,0 / 90 A
fuses	1 x 25 A	2 x 30 A	2 x 30 A	2 x 20 A	2 x 30 A	3 x 30 A
Dimensions (mm)	70 x 230 x 268	70 x 312 x 268	70 x 357 x 268	70 x 357 x 268	70 x 372 x 268	70 x 437 x 268
Dimensions (inch)	2,92 x 9,06 x 10,55	2,92 x 12,28 x 10,55	2,92 x 14,06 x 10,55	2,92 x 14,06 x 10,55	2,92 x 14,65 x 10,55	2,92 x 17,2 x 10,55
Weight	2,7 kg / 6,2 lb	3,6 kg / 7,9 lb	4 kg / 9,2 lb	4 kg / 9,2 lb	4,2 kg / 9,3 lb	5 kg / 11 lb

DLS Performance	CAD 11	CAD15	CA12
Number of channels	1	1	1
Amplifier class	D (digital)	D (digital)	AB
Power output in 4 ohm (0,2% THD)	1 x 400 W	1 x 550 W	1 x 220 W
Power output in 2 ohm (0,2% THD)	1 x 750 W	1 x 900 W	1 x 400 W
Power output in 1 ohm (0,5% THD)	1 x 1050 W	1 x 1600 W	1 x 500 W
All power ratings at 13,8 Volt			
Signal to noise ratio, A-weighted	>100 dB	>100 dB	>100 dB
Damping factor	>100	>100	>100
Frequency response	15 Hz - 160 Hz	15 Hz - 160 Hz	10 Hz - 35 kHz
Input impedance	10 kohms	10 kohms	10 kohms
Input impedance, high level	100 ohms	100 ohms	100 ohms
High level input with auto start	Yes	Yes	Yes
Input sensitivity	0,15 - 5 V	0,15 - 5 V	0,25 - 5 V
Phase control continuous	0 - 180 degrees	0 - 180 degrees	0 - 180 degrees
Remote bass level control	yes	Yes	No
Bass boost adjustable gain @ 45 Hz	0 - +18 dB	0 - +18 dB	-
Filter subsonic, 24 dB slope	15-50 Hz variable	15-50 Hz variable	15 - 150 Hz variable
Filter lowpass 24 dB slope	15 - 150 Hz variable	15 - 150 Hz variable	50 - 500 Hz variable
Bridge mode master/slave selector	Yes	Yes	No
Built-in fan cooling	Yes	Yes	Yes
Power consumption, idle / max	1,5 A / 120 A	2 A / 160 A	0,8 A / 60 A
Fuse	4 x 30 A	4 x 40 A	2 x 30 A
Dimensions (mm)	70 x 444 x 268	70 x 473 x 268	70 x 312 x 268
Dimensions (inch)	2,92 x 17,48 x 10,55	2,92 x 18,6 x 10,55	2,92 x 12,28 x 10,55
Weight	5,8 kg / 12,79 lb	6,4 kg / 14,33 lb	3,8 kg / 8,4 lb

FILTER CONFIGURATION CA 41 & CA 51

Ch. A & B
 High-pass 15 - 500 Hz*
 Low-pass 50(500) - 500(5k) Hz*
 (x 10 switch)

Ch. C & D
 High-pass 15(150) Hz - 500(5k) Hz*
 (x 10 switch)

Ch. E (only CA51)
 Low-pass 60 Hz - 120 Hz
 Subsonic 25 Hz*

*can be switched in/out

CROSSOVERS

The ideal speaker, able to reproduce all frequencies from lowest bass to highest treble, is not yet invented. Instead we have to use two or more speakers where each speaker is reproducing a part of the frequency range.

To make this work the input signal to each speaker driver must contain only the frequencies it's designed for. For this purpose we need crossover filters.

ACTIVE CROSSOVERS

Crossovers can be ACTIVE or PASSIVE. An active filter is connected before the amplifier line input. You need one amplifier for each speaker pair which will become rather expensive.

But the advantages are that it's possible to mix speakers with different impedance or sensitivity and still be able to balance the system.

Most amplifiers are equipped with built-in active crossovers that can be adjusted in frequency and also switched in-out.

All DLS amplifiers have built-in active crossovers.

PASSIVE CROSSOVERS

Passive crossover consists of coils and capacitors, and sometimes resistors for impedance adaption. A passive filter is connected between the amplifier and the speaker and is of LC-type, (coil and capacitor).

A coil stops the higher frequencies while the low passes through, a capacitor works in the opposite way. By changing the component values, different crossover frequencies are obtained. The coils must be of high quality with a large wire area to avoid losses and distortion. Air coils without iron core are the best but they can be rather big for high values. For high values we often use coils with an iron core. The best capacitors are of polyester type. For large capacitance values bipolar electrolytic capacitors are used.

Resistors are used in a filter for impedance adaption. Read the part about conjugate compensation.

A passive filter steals more power than an active.

CROSSOVER FREQUENCIES:

In a two-way system with separate tweeter a crossover frequency from 3 - 8 kHz is normal.

In a three-way system it's normal to split the sub at 200-400 Hz and the tweeter at 3 - 8 kHz.

In a four-way system the x-over frequencies can be as follows. To the subwoofer 80-130 Hz, mid-bass 400-600 Hz and the tweeter 3 - 8 kHz.

This is a just a recommendation. Depending upon the speaker data and where the different elements are mounted in the car, other x-over frequencies could be better.

CROSSOVER EXAMPLES:

(without conjugate compensation)

3-WAY SYSTEM:

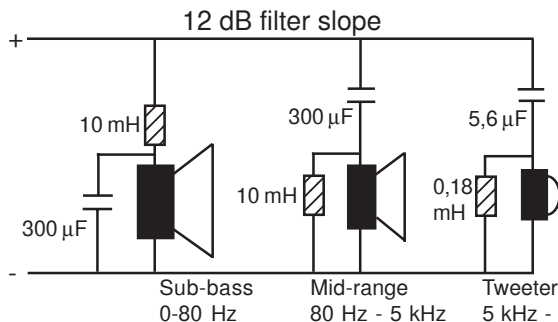

4-WAY SYSTEM:

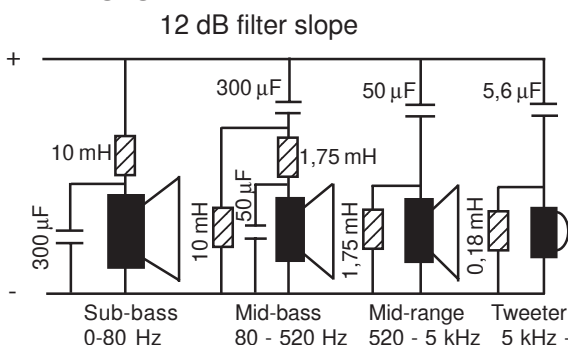

The systems above are shown without impedance compensation. Read below about conjugate links.

PHASE SHIFT IN PASSIVE CROSSOVERS

All passive crossovers will phase shift the signal. A 6 dB filter shifts 90 degrees and a 12 dB 180 degrees. Because of this you should always try to phase reverse the tweeter in a system to see what phase is creating the best sound. In a 3-way system it's normal to phase reverse the tweeter. All tweeters used in a system must have the same polarity (phase). Also subwoofers with a 12 dB crossover should you try to phase reverse. If the subwoofer cone is moving but you don't achieve any good bass you can try to phase reverse. If two subwoofers are connected with different polarity (phase), the sound from each speaker will kill the sound from the other, resulting in a poor bass reproduction.

CONJUGATE COMPENSATION:

Conjugate compensation is a way to equal the speaker load over the whole frequency range. A 4 ohm speaker can have an impedance peak up to 25 times the normal at the resonant frequency (F_s). To make the calculated crossover filter to match, you can connect a conjugate link in parallel with the speaker. It's normally made of a capacitor and a resistor. If you cant calculate the exact component values for the conjugate link you can use a 33 µF capacitor in series with a 3,9 ohm resistor to most 4", 5,25" and 6,5" speakers.

PASSIVE 6 dB LOW-PASS

A 6 dB x-over filter has a 6 dB slope / octave. The output from an amplifier is only a quarter after falling with 6 dB. A 6dB filter is also called 1:st order filter. A common use for a 6 dB low-pass filter is for a subwoofer to stop frequencies over, as for example, 100 Hz.

A 6 dB low-pass filter consists of a coil. The x-over frequency is decided by the inductance value measured in the unit Henry (H) and parts of a Henry. For speakers we normally use coils with the unit mH. 1 H = 1000 mH.

1:st order 6 dB low-pass filter:

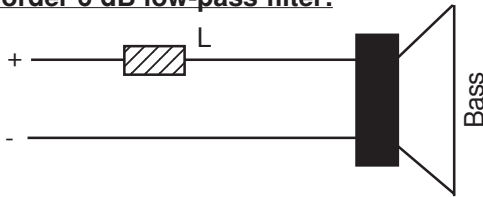

CALCULATION FORMULA:

$$L \text{ (mH)} = \frac{160 \times Z}{F_c}$$

Z = speaker impedance in Ω
 Fc = x-over frequency in Hz
 L = Coil inductance in mH

When connecting coils in series the values are added.

Use this formula when connecting in parallel:

$$\frac{1}{L} = \frac{1}{L} + \frac{1}{L} + \frac{1}{L}$$

Inductance values for different x-over frequencies:

X-over fq. Hz	Speaker impedance		
	2Ω L (mH)	4Ω L (mH)	8Ω L (mH)
65	5	10	20
80	4	8	16
100	3,2	6,4	12,8
130	2,5	5	10
200	1,6	3,2	6,4
360	0,9	1,75	3,5
500	0,65	1,3	2,6
800	0,4	0,8	1,6
1000	0,32	0,64	1,28

X-over frequencies at given values:

	10 mH	6,3 mH	1,75 mH
2Ω	32 Hz	50 Hz	183 Hz
4Ω	64 Hz	101 Hz	365 Hz
8Ω	128 Hz	203 Hz	730 Hz

PASSIVE 6 dB HIGH-PASS

A 6 dB high-pass x-over filter consists of a capacitor. The crossover frequency varies with the capacitor value that is measured in the unit Farad and parts of Farad. Normally we use μF values for speakers., 1 F = 1000 000 μF

Capacitor values from approx. 10 μF and up are normally of bipolar electrolytic type. For lower values we often use polyester capacitors. A capacitor as in the drawing below let the high frequencies pass and stops the lower.

1:st order 6 dB high-pass filter:

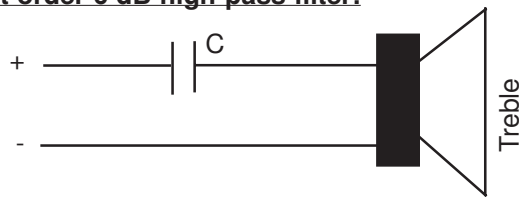

CALCULATION FORMULA:

$$C \text{ (}\mu\text{F)} = \frac{160000}{F_c \times Z}$$

Z = speaker impedance in Ω
 Fc = x-over frequency in Hz
 C = Capacitor value in μF

When connecting capacitors in parallel the values are added. Use this formula when connecting in series.

$$\frac{1}{C} = \frac{1}{C} + \frac{1}{C} + \frac{1}{C}$$

Capacitor values for different x-over frequencies:

X-over fq. Hz	Speaker impedance		
	2Ω C (μF)	4Ω C (μF)	8Ω C (μF)
80	1000	500	250
100	800	400	200
130	600	300	150
200	400	200	100
500	160	80	40
800	100	50	25
1000	80	40	20
2000	40	20	10
5000	16	8	4

X-over frequencies at given values:

	300 μF	200 μF	150 μF	50 μF	6,8 μF
2Ω	266 Hz	400 Hz	533 Hz	1,6 kHz	11,7 kHz
4Ω	133 Hz	200 Hz	266 Hz	800 Hz	5,85 kHz
8Ω	67 Hz	100 Hz	133 Hz	400 Hz	2,92 kHz

PASSIVE 12 dB LOW-PASS

A 12 dB x-over filter has a 12 dB slope / octave.

A 12 dB filter is a combination of a coil and a capacitor. It is also called 2:nd order filter. 12 dB low-pass filters are often used for subwoofers in order to stop frequencies over the x-over frequency, for example 100 Hz. A combination of a low- and high-pass filter is called a band-pass filter.

2:nd order 12 dB low-pass filter:

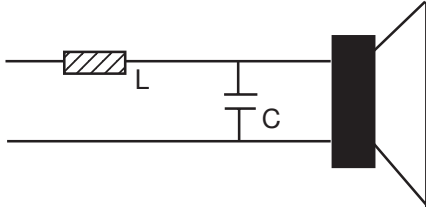

CALCULATION FORMULA:

$$L \text{ (mH)} = \frac{225 \times Z}{F_c} \quad C \text{ (\mu F)} = \frac{112500}{F_c \times Z}$$

Z = speaker impedance in Ω
 Fc = x-over frequency in Hz
 L = coil inductance in mH
 C = capacitor capacitance in μF

When connecting coils in series the values are added. Use this formula when connecting in parallel:

$$\frac{1}{L} = \frac{1}{L} + \frac{1}{L} + \frac{1}{L}$$

PASSIVE 12 dB HIGH-PASS

The difference between the passive 12 dB high-pass x-over filter and the low-pass filter is that the coil and capacitor change place. For a certain x-over frequency the component values are the same for both high- and low-pass filters. A high-pass filter let high frequencies pass, and stops the lower.

2:nd order 12 dB high-pass filter:

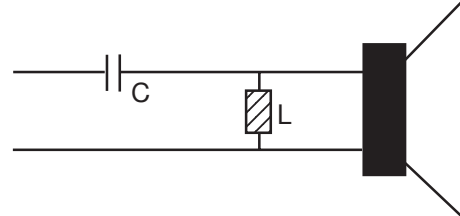

CALCULATION FORMULA:

$$L \text{ (mH)} = \frac{225 \times Z}{F_c} \quad C \text{ (\mu F)} = \frac{112500}{F_c \times Z}$$

Z = speaker impedance in Ω
 Fc = x-over frequency in Hz
 L = coil inductance in mH
 C = capacitor capacitance in μF

When connecting capacitors in parallel the values are added. Use this formula when connecting in series.

$$\frac{1}{C} = \frac{1}{C} + \frac{1}{C} + \frac{1}{C}$$

COMPONENT VALUES FOR 12 dB PASSIVE CROSSOVERS

X-over freq. in Hz	2 Ω		4 Ω		8Ω	
	C (μF)	L (mH)	C (μF)	L (mH)	C (μF)	L (mH)
62,5	900	7,2	450	14,4	225	28,8
95	600	5	300	10	150	20
140	400	3,2	200	6,4	100	12,8
190	300	2,35	150	4,7	75	9,5
375	150	1,2	75	2,4	38	4,8
520	108	0,87	54	1,75	27	3,5
800	70	0,56	35	1,12	18	2,25
3500	16	0,12	8	0,25	4	0,5
5000	11	0,09	5,6	0,18	2,8	0,36

The same component values are used for both high- and low-pass filters, but they change place.

Use coils with low resistance, air coils are the best. Coils with iron core must be able to handle high current or the iron core magnetic saturation becomes to high causing distortion. Capacitors must be of bipolar type, 50 - 100 Volt.

IMPORTANT WHEN CONNECTING FILTERS!

When connecting a 12 dB low-pass x-over to a subwoofer it's suitable to solder the capacitor directly on the sub terminals between + and -.

If the sub is disconnected without disconnecting the capacitor at the same time the amplifier can be damaged.

A 12 dB filter connected without a speaker will overload the amplifier (if it's turned on) and damage the output circuits.

THE CABLES - AN IMPORTANT LINK

No chain is stronger than it's weakest link !

It's not unusual that people buy expensive amplifiers and speakers but forget the wiring. DLS have high quality cables for both amateurs and professional users.

Cables made of oxygen free copper (OFC).

Cables made of oxygen free copper will not oxidize as normal copper do. The oxidation increases the DC-resistance and as a result of this the voltage drop in the cable. All DLS cables use oxygen free copper.

DLS POWER CABLES.

As we have said before the DC-feed to the amplifier is of great importance. The amplifier must in all occasions have enough current, otherwise both the dynamics and good sound will be lost.

DLS power cables of oxygen free copper are made of a lot of small cores to make it soft and flexible with lowest DC-resistance. Use the table below to choose the correct DC-feed.

Cable length:	≤1,5 m	1,5 - 5 m	> 5 m
CA22/ CA23/CA12	10 mm ²	16 mm ²	21 mm ²
CA31/CA41/CA51	16 mm ²	21 mm ²	33 mm ²
CAD11, CAD 15	16 mm ²	21 mm ²	33 mm ²
RA20/RA30/RA40	16 mm ²	21 mm ²	33 mm ²
A1 / A2 /A8/RA25	10 mm ²	16 mm ²	21 mm ²
A3 /A4 / A5 / A7	16 mm ²	21 mm ²	33 mm ²
A6/RA10/RA50	21 mm ²	33 mm ²	50 mm ²

In many installations the current capacity is improved with extra batteries (OPTIMA) with low inner resistance or large 1 Farad capacitors, DLS Power Caps. If you don't want to spend money on extra batteries at least you shouldn't save money on the DC-feed.

DLS SPEAKER CABLES.

Also the speaker feed must be of high quality. Use cables with an area of at least 1,5 mm². DLS speaker cables are soft and flexible with a construction that minimizes the loss over the whole frequency range.

DLS SC 4x1 and SC 4x1,5 are special speaker cables with four leads. They are twisted and has a powerful insulation protecting them from mechanical agitation. The four leads are connected in pairs as they have different strand sizes using the skin effect to minimize the resistance on all frequencies. The capacitance, inductance and EMF are reduced by the twisted cores in the cable. Two of the four leads have a strand size of 0,1 mm², and the two others have 0,2 mm².

DLS SCP, SCK and SCKS are other types of cables that offer these advantages. The **SCKS** uses silver plated aluminium strands and offers the best sound quality for all purposes.

DLS SC 2x1,5, SC 2x2,5 and SC 2x4 are the standard two-lead speaker cables made of oxygen free copper. They have twisted strands and are soft and flexible for easy installations.

SKIN-EFFECT AND INDUCTANCE

In a conductor the higher frequencies moves on the surface, while lower frequencies moves in the center of the cable. To make the active resistance (impedance and inductance) as low as possible for each frequency some cables use different strand sizes for different frequencies. Higher frequencies prefer a cable with very thin strands while the lower frequencies will find the lowest active resistance in a thicker strand. To minimize the cable resistance further the cable can be designed with a combination of copper and silver plated strands.

One of the advantages with DLS speaker- and signal cables are the low inductance. Opposite an ordinary DC-resistance the inductance is linear. It means that higher frequencies will be more suppressed than the lower which can create a distorted and false sound reproduction. Inductance will occur when an AC-current flows in an electromagnetic field. These fields are causing eddy currents superposed the normal current leading to an increase of resistance. They also make the current flow to decrease towards the center of the conductor (skin-effect). A low inductance is to prefer. This is achieved by using raw materials with high purity. A low inductance will also be achieved by twisting the strands in the conductor. When the current to the speaker passes through the speaker coil, which is an inductance, it creates eddy currents that goes back to the amplifier called counter- Electro Motive Force (EMF). The EMF is also reduced by a correct cable construction with twisted strands.

DLS speaker cable design gives the following advantages:

- Maximum reduction of the EMF which causes phase shift resulting in bad sound quality.
- Lowest possible damping resistance on all frequencies by using the skin effect.
- Lowest possible power loss.

SIGNAL CABLES:

The signal cables must be of good quality as well as the speaker cables. The construction of the cable must have the best possible reduction of inductance and capacitance together with a low damping over the whole frequency range.

The shielding is also important to avoid interference noise from the electric system of the car.

DLS SL2PRO and **SL5PRO** are triple shielded but without a remote wire. A remote wire included with the signal cable may induce interference. These cables are also quasi-balanced for maximum performance. Also use RCA phono connectors of highest quality with good shielding and gold plated for minimum contact resistance.

DLS ULTIMATE signal cables are of balanced type and are often used by very critical listeners. The best performance is achieved by the **ULTIMATE** silver cables that uses silver plated strands.

INSTALLATION

THE HEAD UNIT

The heart in a car stereo installation is the car stereo, often called head unit. Today it's normally a tuner with an external CD-changer or built-in CD-player. The well-known brands are the best choice if you want a high quality product.

One important detail is to buy a head unit with RCA pre-outs which makes it easier when you want to do a more sophisticated installation than standard. The head unit is normally installed in the dash-boards original fitting, just make sure it's fastened properly. If possible use heavier DC-feeds than the originals used in the car. If you use the internal amplifier to feed any speaker pair this is important. The ground wire must have the same area as the +-feed.

If you have interference noise from the alternator or ignition it's often the ground connection that is wrong. Try different places for the ground connection, the best is close to a unit (the amplifier).

THE AMPLIFIER

An extra amplifier should be installed in a place where it can be satisfactory cooled. Many amplifiers get very hot and need a good cooling.

In some installations you might need one or two external cooling fans.

First check if there are any cable mats or fuel pipes behind the place where you plan to mount the amplifier. Alternatively use an extra particle board or the bass box when you mount the amplifier and you will have a better ground insulation. To avoid interference noise this can be to prefer.

Install the amplifier far away from your radio aerial. Sometimes the amplifiers DC/DC-converter generates high frequency interference.

THE CABLES

As we have said before the cables are very important. In the table on page 5 you find recommended areas for the DC-feed for different amplifiers. The ground wire must have the same area as the +-wire. Connect the ground wire as close as possible to the amplifier. Connect all units in the system to the same ground point to avoid interference.

Use high quality speaker cables with an area of at least 1,5 mm² to the side systems and 2,5 mm² to the subwoofers, (or more).

Signal cables must have good shielding, otherwise they can pick up interference noise.

Avoid to place the power cables on the same side of the car as the signal cables. Also try to avoid the cars own cable mats to come close to the signal cables.

Any extra cable must be laid out in zig-zag style and definitely not coiled.

Don't let the cables pass sharp edges that can hurt the cable insulation causing short circuits or other problems.

THE DC-FEED

Maximum fuse values of the main fuse for different cable sizes.

6 mm ² (9 AWG) : 25 A	10 mm ² (7AWG) : 40 A
16 mm ² (5AWG) : 60 A	21 mm ² (4AWG) : 100 A
33 mm ² (2AWG) : 150 A	42 mm ² (1AWG) : 200 A

To avoid damage to the amplifier or the electric system of the car the DC-feed installation must be made with care. A main fuse must be installed on the power line close to the battery. This fuse protects the cable from burning if a short circuit occurs.

Use either glass fuses or automatic circuit breakers. If the amplifiers are installed in the back of the car it's normal to install a separate fuse block from which you distribute the power to the separate units. Each unit will then be separately fuse protected.

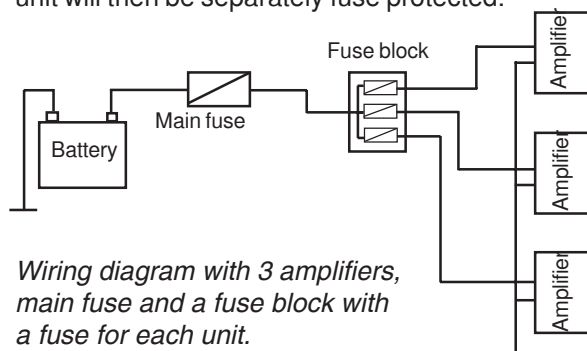

Wiring diagram with 3 amplifiers, main fuse and a fuse block with a fuse for each unit.

The main fuse holders use either a glass fuse of AGU-type (max 80A), or ANL-fuses with values up to 250 Amps. There are fuse blocks for 2, 3 or 4 AGU fuses. Automatic circuit breakers is another good alternative as main fuse. They also have a test button with which you easily can switch off the power to all units.

The ground wires from all units can easily be connected together with a power block like the PB1.

For best function with lowest possible DC-resistance in all connection points, all the above products are gold plated with 24 K gold. Besides of a good function it's also gives a good impression.

EXTRA BATTERY

In many exclusive installations, and most competition cars, extra batteries are installed. Sometimes also extra alternators for improved charging, or extra capacitors of 0,5 or 1 Farad value.

The purpose of this is to make sure that the amplifiers always gets enough current even at very high volumes, otherwise the sound will be destroyed at high volumes.

For a normal listener the ordinary car battery is sufficient. Just make sure you have DC-feeds that's big enough. But if you plan to compete or just want to get the most out of your equipment it's always right to install an extra battery or extra capacitors that works as a current reservoir.

These extra battery's are of a special type with low internal resistance that can handle large current flows.

SPEAKER INSTALLATION

An important part of the installation is of course the speakers.

How they are installed varies from car to car and depends upon the possibilities in each type.

The factory pre-made installation holes are not always ideal for other types of speakers than original. We will give you some hints of what to think of when installing speakers.

ORIGINAL INSTALLATION

The easiest way to install a speaker in a car is to use the factory pre-made holes. If you use car specific speakers, the installation job becomes very easy. But the problem is that these type of speakers are usually not of the highest quality and will not satisfy a demanding listener.

The high quality speakers often have large magnets making it necessary to first measure the space and sometimes make changes in the door or dash-board to make them fit. Especially the depth is important to check so that the side windows goes clear from the magnet.

Some car models requires special adaptors or distances to make the speaker fit when you use other speakers than the original.

If possible use some kind of baffle on the back of the door panel. Make sure the baffle is fastened properly and fasten the speaker in the baffle. This is easy to make and will normally result in a better sound than without baffle.

A speaker installation high up on the door-side is to recommend, but if the pre-made hole is at the bottom part of the door it's difficult to change.

A 2/3-way system should be installed with the elements close to each other to achieve the best sound image. An alternative is to install the bass element in the door and the tweeter on the dash-board.

A door or dashboard installation is actually an "open-air" installation since there is no limiting box.

ORIGINAL MOUNTING:

ADVANTAGES:

- Fast, easy and simple

DISADVANTAGES:

- The speakers have no baffle = rattle.
- Bad power handling capacity.
- Bad sound image.



Example of a door installation with new baffles.

NEW DOOR Baffles

If you want to improve your door installation you should build a new door-side. This must be adapted to the door side and is normally made of MDF or particle board. The baffle is covered with cloth or vinyl matching the car interior. Some car sound builders changes the whole door-side to a new one. The speaker element is directed to obtain the best sound image. They are also fastened properly to avoid rattle.

They are normally mounted with a sealed speaker box behind the elements. The volumes needed for a 4" or 5,25" element are only a few liters.

BAFFLE MOUNTING:

ADVANTAGES:

- The speakers are mounted in real baffles.
- A box construction that improves the sound quality with less rattling.
- Higher power handling capacity.
- Better sound image (front stage).

DISADVANTAGES:

- More work and more expensive mounting.
- The cars original door sides are affected.
- The installation requires a lot of knowledge to make the installation to look professional.

KICK-PANELS

Another installation alternative giving a good sound image is the kick-panel. It's placed down on the floor in front of the door on both sides. It can contain the whole system with bass, midrange and tweeter or a bass and midrange with the tweeter installed on the dashboard. The best places for the speakers must be tested out in the respective car.

Kick-panels are normally made of MDF or particle board and are build as sealed boxes or as membrane boxes where the element is allowed to breath through a membrane of foam rubber or similar.

Kick-panels are very popular in competition cars.

MOUNTING IN KICK-PANELS:

ADVANTAGES:

- Stable mounting without rattling.
- Superb sound image.
- Higher power handling capacity.
- Less affection on the cars interior.

DISADVANTAGES:

- More mounting work.
- Possibilites to damage the speaker if kicking on them with the feet.

HIGH MOUNTED KICK-PANELS:

In some cars the kick-panel can be mounted invisible up under the dashboard. Can create a good sound image despite the strange mounting.

DASHBOARD MOUNTING

A mounting of the midrange and tweeter up on the dashboard will result in an improved sound image. It will be moved up on the dashboard. Some cars that have suitable original dashboard mounting holes can be used.

The tweeters should be mounted on the dashboard or on the door poles. The woofer elements should be mounted in a door-side or in a kick-panel. Suitable for DLS C36, UR35i/UR36i, UP-35/UP-36 or Iridium 6.3 / 8.3.

REAR FILL

A well mounted front system is the most important in a sound system. In some cases we also use rear mounted speakers used as "rear fill". Rear fill speakers will improve the front stage image by adding a weak sound from the rear filling up the sound stage and giving it a deep. As Rear fill speakers we can use midrange elements in combination with a passive or active bandpass filter, mounted in the rear. A suitable frequency response can be from 500 - 6000 Hz. The level must be dampened easiest made with a series resistor of 10 - 20 ohms in series with the + lead. The rear fill speaker can also be connected in multimode. In this case you use only one element working as a center channel speaker.

CENTRE CHANNEL SPEAKER

A centre channel speaker can be used to improve the sound image in installations where the speaker mounting makes it difficult to achieve a correct sound image.

On a DLS amplifier the centre speaker is connected in bridge mode between Left and Right channel. The speaker is now fed with the sum signal from left and right channel. This will fill in what you can call the gap in the soundstage of the earlier installation.

Your side system will hopefully be good 6,5 inch coaxes or two-way systems or even better. A small centre channel speaker of smaller size will have to be feed at a lower level of volume.

In this example the signal is dampened with a 20 ohm resistor. The level can then be adjusted with the variable resistor. The component values can need to be changed sometimes.

The frequency response in this example is between 550 - 6000 Hz. The component values can be changed if you want another frequency response.

In amplifiers with built-in highpass and lowpass filters, you can use these instead of the passive band-pass filter. A 5-channel amplifier like the CA51 is suitable in this case.

Here is a description of a passive bandpass filter for a 4 ohm speaker.

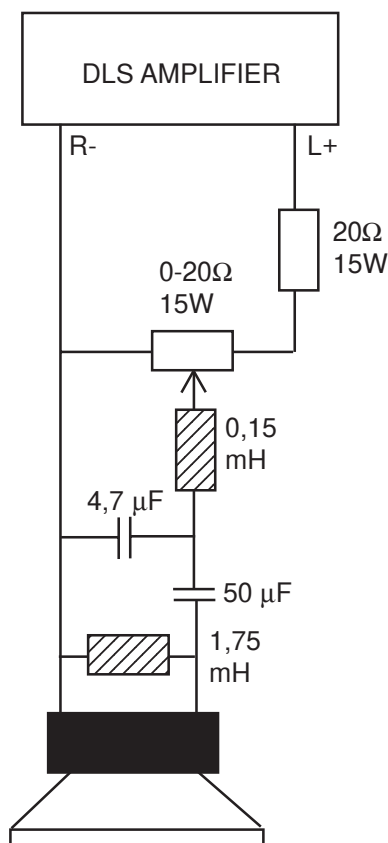

Centre channel speaker 4 ohm

HAT-RACK MOUNTING

The best sound stage for front seat listeners is achieved with door- or kick-panel mounting. In competition cars the front system combined with rear subwoofers are often the only speakers. Sometimes they are combined with a pair of small 4" or 5,25" speakers in the back used as "rear fill". These rear fill speakers are connected with x-overs giving a reproduction from 1-2 kHz and up. Tweeters are normally not used in combination with rear fill.

The traditional hat-rack mounting with a speaker component kit, 6x9" or 7x10" speakers requires some installation work to create a good sound.

A new hat-rack made of particle board (22 mm) or MDF-board (19 mm) must be produced. The original hat-racks are normally not sufficient to use.

If you furthermore want the speakers to have a high power handling capacity you need to make some kind of speaker box (normally of sealed type) on the back of the hat-rack, limiting the cone movement.

If you have a bass box in your trunk it's necessary to have a box for the hat-rack speakers. If not, the low bass from the sub will have an influence on the speaker cones and destroy the sound.

In many installations you must use passive filters to the different speakers in your system. Later in this book there are some wiring examples where passive filters are used.

SUBWOOFER INSTALLATION

An "open air" subwoofer installation in the hat-rack or towards the back seat calls for the same baffles of particle board or MDF-board as described above.

DLS OA10D & OA12D are subwoofers designed to use in open air installations.

But the best result is normally achieved using a separate bass box of some type. Later in this book we will describe different types of boxes and give advices of how to build a box.

You will also find suitable box sizes for all DLS subwoofers.



DLS IN MULTIMODE

All DLS amplifiers (except for A6, RA10 & CAD11) can be used in multimode operation on the stereo channels. Multimode means that you from one amplifier can take three different signals, left channel, right channel and the sum of right and left channel.

To the sum signal you can connect one or more subwoofers through a passive low-pass crossover. You can also connect a center-channel speaker in multimode. (See example on page 18).

The stereo connected speakers can be either a 2/3-way system or coaxial speakers. To this speakers you must use passive high-pass filters that limits the frequency response.

The advantages of multimode operation is that a single amplifier can be used for all speakers in the car. It's easy to install, it needs less space and it's cheaper.

The disadvantages is that you need passive crossovers and it's difficult to adjust the sound balance between the front system and the subwoofer.

The load capacity of the amplifier limits the number of speakers that you can use in the system.

DLS CLASSIC and Reference amplifiers are 2 ohm stable, the minimum amplifier load is 2 ohms. The DLS ULTIMATE amplifiers are 1 ohm stable, minimum amplifier load is 1 ohm.

MULTIMODE OPERATION

This is an example of a typical multimode connection with a front system and a subwoofer. 12 dB passive high- and low-pass filters are used in combination with the original filters used for the front system.

All speakers have an impedance of 4 ohms.

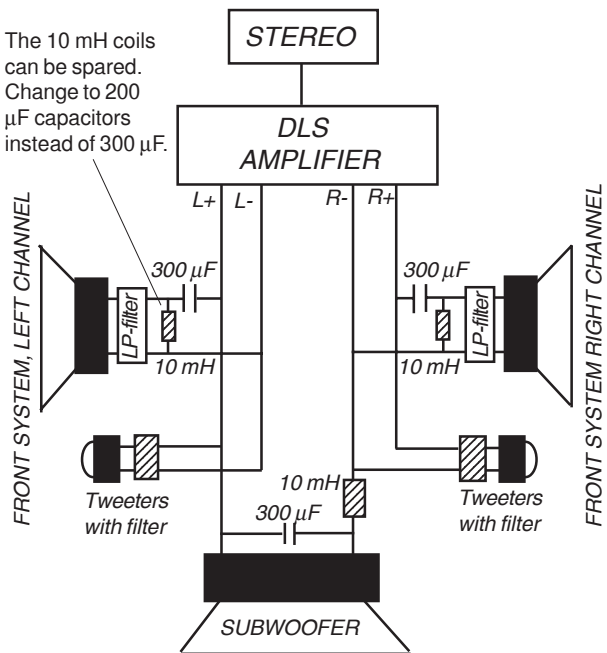

This connection can be used together with all DLS amplifiers.

WHY DO WE NEED SPEAKER BOXES?

A Hi-Fi speaker for home use is always mounted in a box to reproduce the best possible sound.

Traditional mounting in cars are in a door side or in the hat rack, this is a simple baffle mounting. You can of course achieve a better sound in your car by using suitable speaker boxes.

In a correct adapted box the sound is improved and the power handling capacity increases.

If you have a subwoofer in your trunk and a pair of "open air"- mounted speakers in the rear, the air pumping from the sub will effect the rear speakers and make the cones move a little, ruining the sound from them. This is one of many good reasons to use boxes in your car as well as at home.

Normally we use boxes for the subwoofer but also the rest of the speakers sounds better mounted in a suitable box. We will now describe the different types of boxes normally used in a car.

SPEAKER BOXES, GENERAL

Build your box in a stable and air-tight material. The best is MDF-board, 19 mm, or particle board, 22 mm. Larger boxes must have braces inside to avoid resonance. The box must be completely air-tight. Use sealing compound in all joints, also in the conduit entry. The size of the box is fixed by the speaker data, but also the type of vehicle and music, have an influence on the box size. Deep bass demands larger boxes than disco music.

SEALED (CLOSED) BOXES

Sealed boxes are easy to build. The size is not critical, but it can't be too small. The speaker data such as Fs, Qts, Vas and X-max decides the size of the box. Large speakers need larger boxes. Two speakers need a box of the double size etc. The box must be completely air-tight. Sealed boxes are normally used for door-panels or kick-panels. Most 4", 5,25" and 6,5" speakers can be used in sealed boxes.

A sealed box should be filled with acoustic wool up to 75 - 100%. A sealed box has a lower efficiency than vented boxes but they can handle high power and are easy to build. A subwoofer in a sealed box creates a tight bass suitable for the audiophiles listening to classical music, jazz and soft rock.

Advantages:

- High power handling capacity
- Extended low frequency reproduction
- Excellent transient response
- Easy to build
- Not critical with the size

Disadvantage:

- Lower efficiency (needs more power)

If you use a 25-30 Hz subsonic highpass filter on the line input of your amplifier you will achieve a tight and well-defined bass in your bass-box. (All DLS amplifiers have a built-in subsonic filter.)

VENTED BOXES

A speaker in a vented box has higher efficiency (3 dB) than in a sealed box. In a vented box the sound from the speaker and the port work together creating a higher sound level. The sound from the port must come out in the same phase as from the speaker, or the sound result is bad.

The size of the box is set by the speaker data just as in the sealed box. Also the car type and music type have an influence on the box size.

Often the size of the car decides the practical size of the box. A smaller box has a higher resonant frequency than the larger one. The size of the box should not be so large that the speaker plays below it's own free air resonance (Fs), then the power handling capacity drops.

The port in a vented box should be installed on the same side of the box as the speaker. But sometimes this is impossible. The port opening inside the box must have a free area behind the port, to the wall behind, of at least the port diameter.

If the port is very long you might have problems with the install. You can make a trick and "fool" the speaker. Cut the port approx. 2,5 cm (1") from the rear wall inside the box. Then the speaker is fooled to believe the port is longer than it actually is. This is not a perfect method but it often works good enough.

There must also be a free area in front of the port. Don't cover the port opening with cloth. A large sub needs a larger port to avoid whistling sounds. Use ports with conical openings to avoid this. The port must also be fastened properly to avoid rattle.

3" or 4" PVC tubes are normally used for ports. In a correct tuned box you should be able to feel the air pumping out from the port. At high volumes the air can blow out a burning match, if not the box and port are mismatched.

The port does not have to be fully inside the box as long as the area and length are correct. for example you can mount the port through a hat-rack. In a small box this can have an effect on the box tuning since the volume changes.

Suitable port diameters for different speaker sizes:

8":	4 - 8 cm,	10":	6 - 10 cm
12":	8 - 15 cm,	15":	10 - 15 cm

Sometimes you need two or more ports in a box. You can convert from one to two or more ports as long as the total port area is the same.

Advantages:

- Less cone movement and lower distortion at port tuning.
- Higher sound level at port tuning.
- Improved "bass kick".

Disadvantages

- Less cone control below port tuning.
- Higher frequencies can "leak" through the port.
- The sound from the port can be out of phase compared with the sound from the speaker cone. Can give a trailing sub sound.

BANDPASS BOXES

In all bandpass boxes the speakers are hidden inside the box, all sound is coming out through the ports. There are different types of bandpass boxes and they have in common that they are a bit more difficult to build.

BOX DESCRIPTION

Mechanical orders for speaker boxes:

1:th order

Speaker in free air. Not in practical use, the speaker is acoustically shortened.

2:nd order

Speaker mounted on a baffle, normally called "open air".

This is not a box, just a way of mounting the speaker. For example in a hat-rack or behind the rear seat. Can create a good sound with the correct speaker parameters. The speaker should have a low resonant frequency.

3:rd order

Speaker mounted in a sealed box.

A sealed box is easy to build and calculate. It also has a high power handling capacity. On the other hand it has low efficiency and the box must be rather big to create a deep bass. With a rather small box and a 20-40 Hz subsonic filter you will get a box suitable for hard rock with a fast attack in the bass.

4:th order

Speaker mounted in a vented box, often called bass reflex box.

A vented box has a higher efficiency and a higher power handling capacity than the sealed box - but only if it's correctly calculated with a suitable speaker element. Suitable for all kinds of music. The power handling capacity below the F-3db point is rather weak. It is important that the ports are correctly tuned, they must not be too small, then whistling sounds can occur. With a wrong port the sound from the ports comes out phase reversed and causes a blurred sound.

5:th order

Speaker mounted in a sealed box, playing into a vented box.

This type of box can play one octave only, but it has a high power capacity and gives a 3-5 dB raise at it's tuned frequency. Suitable for disco and hard-rock music. Difficult to build and calculate and you can't have speaker cloth in front of the ports.

6:th order

Speaker mounted in a vented box where both the speaker and the port is playing into another ported box.

This box is also difficult to calculate and build. Plays 2 octaves and gives a natural cut-off for higher frequencies with 12 dB/oct. which reduces the audible distortion. It has a high efficiency and power handling capacity. Low F-3dB and a top at the tuned frequencies. Small ports gives a whistling sound and you can't have speaker cloth in front of the port. Build as isobaric it creates a powerful and distinct deep bass.

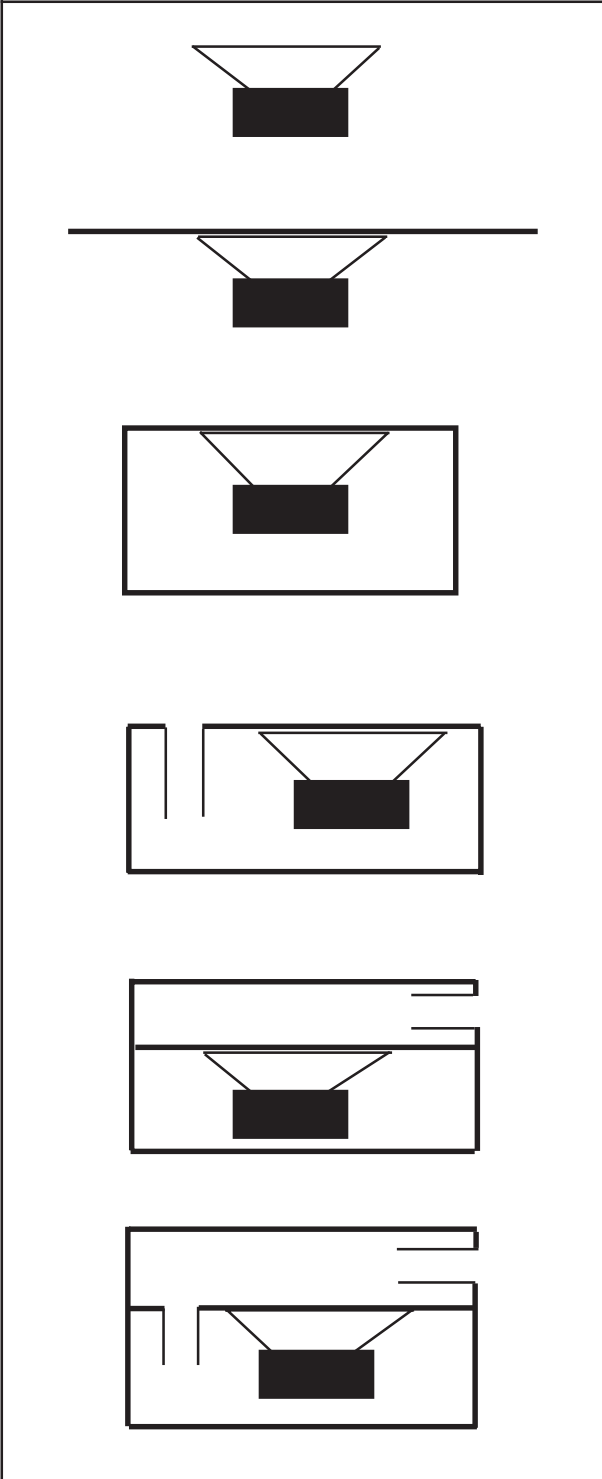
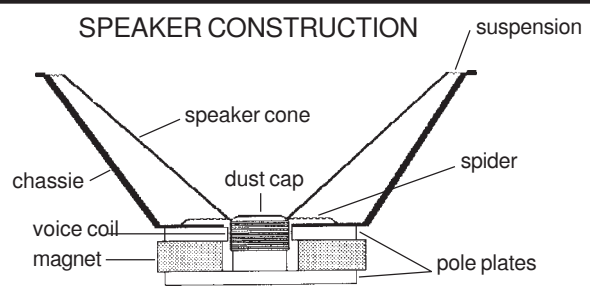

7:th order bandpass box

Speaker mounted in a vented box playing into another vented box. All ports going out.

What is valid for 6:th order boxes is also valid for 7:th order boxes. The difference is that this box gives a 6 - 10 dB peak at the tuned frequencies.

8:th order bandpass box

Speaker mounted in a vented box playing into another vented box with all ports playing into a third vented box.

This type of box becomes rather large but the port openings can be covered with cloth. It has like the 6:th and 7:th order boxes high efficiency and power handling capacity. It also gives a 6 - 10 dB peak at the tuned frequencies.

3-chamber bandpass boxes

Both 5:th order boxes and 7:th order boxes can be built as 3-chamber boxes with two speakers playing into a ported chamber. The picture shows a 5:th order 3-chamber box. In a 7:th order 3-chamber box all chambers have ports.

ISOBARIC BOXES

Two speakers mounted on the same axis and operating in the same phase and direction (push and pull).

All box types can be built isobaric giving the following advantages and disadvantages.

Advantages: Reduced box volume with the same F-3 dB
Higher efficiency
Lower distortion

Disadvantages: Difficult to build and calculate
The speaker specifications changes (Qts and Vas)

Isobaric-connection:

Isobaric speakers are connected with the inner sub in phase with the outer, but phase reversed as in the drawing below.

If both are in boxes the one in the smallest box should be phase reversed.

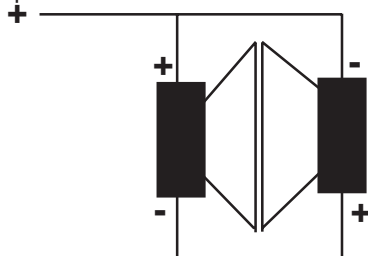

Speakers in parallel

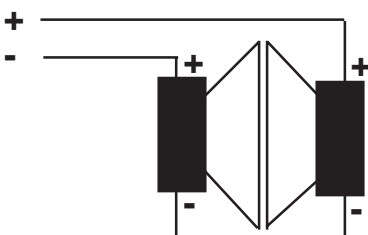

Speakers in series

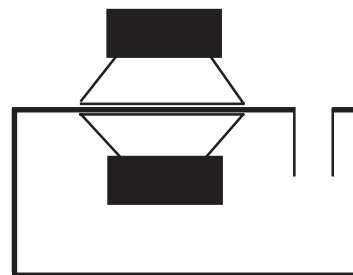
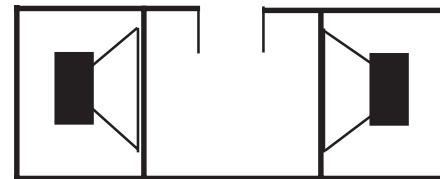
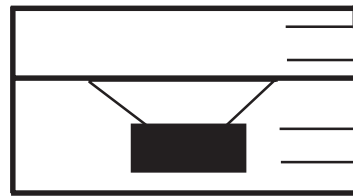

4:th order isobaric box

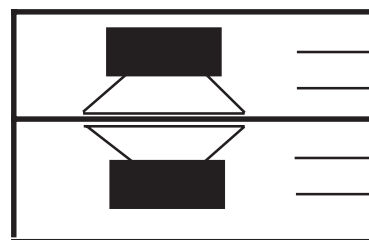

7:th order isobaric bandpass box



Use DLS BP-75 and BP-110 conical ports to avoid port noise.

SPEAKER LOADS

Most car audio speakers have a 4 ohm impedance. DLS CLASSIC and Reference amplifiers can handle loads down to 2 ohm on each stereo channel. DLS ULTIMATE amplifiers can handle loads down to 1 ohm. If you are using more than one driver they must be connected in a way so the impedance still is 4 ohm when connected to a CLASSIC amplifier in bridge mode. To an ULTIMATE amplifier you can connect speakers in bridge mode that has an impedance of only 2 ohms. When you run the amplifier in mono bridge mode it sees a 4 ohm load as 2 ohm, and a 2 ohm load as 1 ohm.

Below you find different speaker wiring examples.

Two 4 ohm speakers in parallel

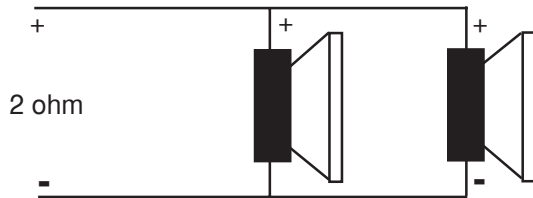

Two speakers in series.

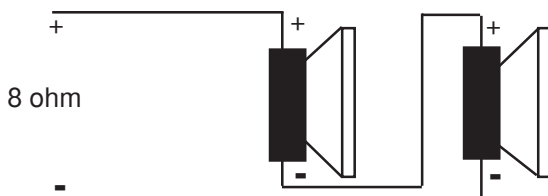

We don't recommend this connection.

Four speakers in series/parallel to 4 ohm.

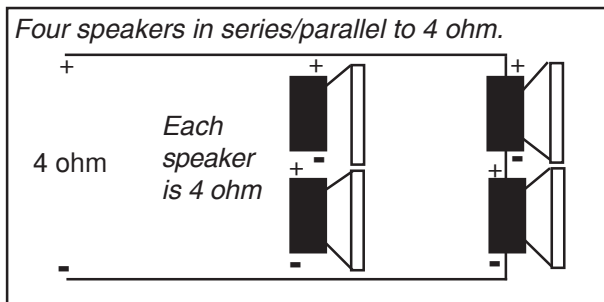

Three speakers in parallel

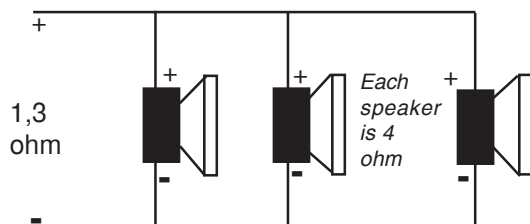

SPEAKER CONNECTION

Always use high quality speaker cables such as **DLS SC 2x1,5**, **SC 2x2,5** or **SC 2x4**. Subwoofer connection requires 2 x 4 mm² cable.

Connect the speaker + (marked with + or a red dot) to the amplifier + terminal, and the speaker - to the amplifier -.

When fitting the cables to the amplifier terminals, remove only 10 mm of the insulation. Twist the wire strand together and insert the wire after loosening the terminal screw. Do not over tighten as this can cut the cable strands.

If you want an extra high class speaker cable choose any of the DLS SCP, SCK, SCKS, SC 4x1 or SC 4x1,5 cables.

SPEAKER POLARITY CHECK.

All speakers in a car audio system should be connected in phase (the same polarity). All speaker cones must move in the same direction. Out of phase speakers will cause a lack of bass, and a poor stereo soundstage.

Checking polarity:

Hold the - connection of the speaker wire to the - terminal of a 1,5 Volt flashlight battery. Tap the + wire on to the + terminal of the battery, and observe the movement of the cone. The cone should move outwards when the wire touches the battery, and inwards when the battery is removed. If it is the other way around, the speaker has been connected backwards and it must be removed and connected correctly.

If your system also has a subwoofer connected through a passive 6 or 12 dB crossover, try to connect this with various polarity and judge what sounds best. The phase shift in passive crossovers sometimes makes it necessary to change polarity.

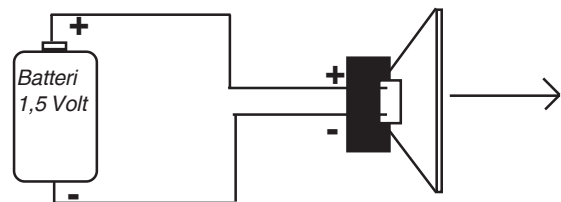

NOTE! You can not test tweeters in this way.

Installing car sound can sometimes cause problems. If you are not satisfied with the sound you could have made something wrong. Some typical problems are described below with hints for solving them.

1. Problem: Poor bass reproduction despite of a correctly designed bass box.

- Start with phase reversing the subwoofer to see if this helps.
- If you are using more than one subwoofer make sure they are connected in the same phase (polarity), if not most bass sound disappears. (The speaker cones are moving but will not create bass sound).
- If the bass reproduction is improved when opening the doors of your car the box is too large, The F-3dB point is too low. Make the box smaller.
- Standing waves can "kill" some frequencies. Try to change place for the box. You can also try to make the bass port shorter, this will increase the box resonant frequency. In some cases the area under the dashboard can work as a wave trap killing some low frequencies. Try to fill this area and tighten it.
- Also check the signal cable. If your subwoofer is connected in mono bridge mode and one of the leads are broken in a signal cable the sound becomes real bad.
- You must also have enough power, especially if you have a small sealed enclosure the power output should be at least 200 Watts RMS.

2. Problem: The real "kick" lacks in the bass sound.

- The box is not correctly build, or the box is not air tight.
- The sub amplifier does not get enough power, the power cables are too small, the ground connection bad, or some other things that is causing voltage drop at high power outputs. A cheap amplifier with insufficient capacity in the DC-converter can give the same result. A good car battery with low inner resistance (OPTIMA) or a Power Cap of 0,5 Farad or more connected to the power lead will also improve the bass reproduction.

3. Problem: "Rumble" bass sound.

- The box tuning is too low, make the F-3dB higher with a smaller box.
- Connect a subsonic high-pass filter, 30 - 50 Hz, in series with the amplifier input.
- Use vented or sealed boxes. Avoid band-pass boxes, they are more difficult to build, and if they are incorrectly designed they create a rumble bass sound.

4. Problem: Poor bass reproduction in a system without separate subwoofer.

- Is normally caused by incorrect speaker phasing. Make sure all woofer elements in the system are connected with the same polarity (phasing). Both front and rear speakers. This is easiest made with the use of a 1,5 Volt battery. Connect the battery + to the speaker + cable, and the - to the speaker - cable. All speaker cones must move outwards when the battery is connected.

5. Problem: Interference sound from the alternator in systems with a separate amplifier.

- Is normally caused by incorrect grounding. Try to connect all units to the same ground point. It should be a place close to the amplifier where the paint is removed from the metal surface.
- Poor shielding on the signal cables, or a defective cable.
- The signal cable is placed close to the cars own cable wiring inducing interference into the signal cable.
- The input level control on your amplifier is set to high, reduce the setting.
- Any extra cable must not be laid in a ring, shorten the cable or lay it in zig-zag instead.

BASS BOXES IN DIFFERENT TYPES OF CARS

1. SMALL CARS LIKE VW GOLF AND SIMILAR

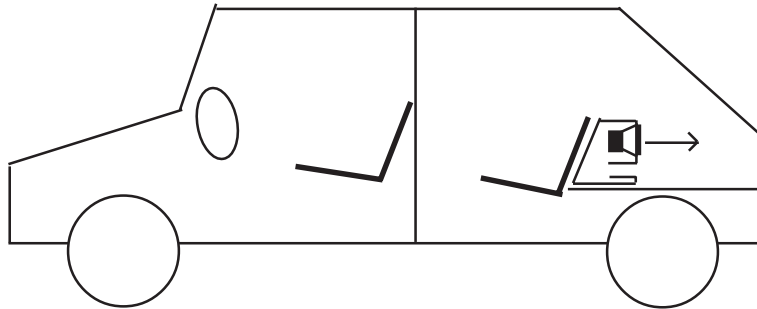

In this car type the bass box should be mounted with both speaker and port directed backwards. Alternatively both speaker and port can be directed upwards. This way of mounting is valid also for half-combi car types.

2. SEDAN CARS

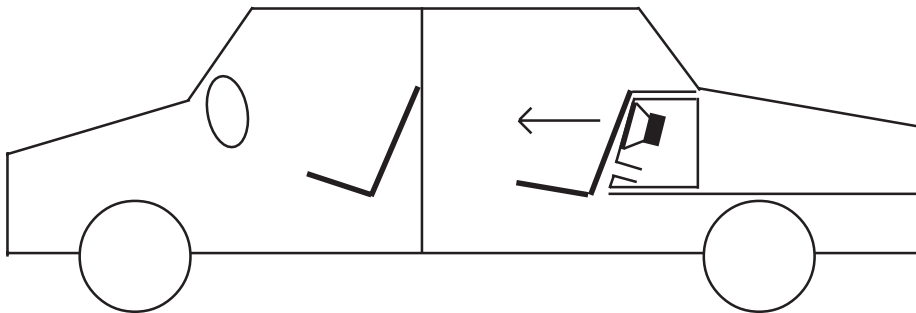

In this car type with the passenger compartment separated from the luggage compartment the bass box should be mounted with both speaker and port directed towards the rear seat. In some cars there is an opening in the middle of the rear seat for loading skis etc. You can place the box behind this opening and direct speaker or port through this opening. There must be some free space in front of the port, (between the rear seat and the port opening)

Don't put the port through the hat rack if the speaker is directed towards the rear seat, this will give a poor sound. Alternatively you can mount both speakers and port in the hat rack with a box under it, but this requires more changes of the car original interior.

3. LARGE CARS, STATION WAGONS.

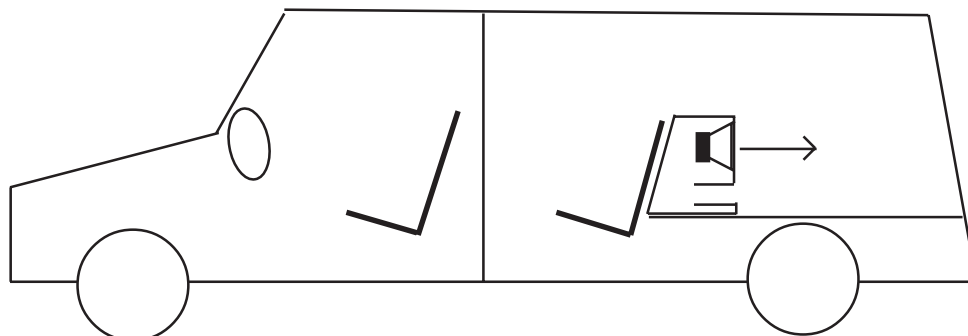

In this type of cars the best sound is achieved with the bass box mounted behind the rear seat with both speaker and port directed backwards. Alternatively you can put the bass box on one side of the luggage compartment.

SOME ADVICES FROM DOCTOR "BACKE"

When building a bass box the following are very important:

The box must be very steady and completely air-tight. Use 22 mm particle board or 19 mm MDF-board. The particle board has a self resonant frequency of 14 Hz while the MDF has a resonant frequency of approx. 400 Hz. Its important to stabilize the box inside with some braces, especially the boxes made of MDF could cause "PLONK"-sounds if it's not sufficiently braced.

If you are using a milling machine its better to use MDF-board since particle board wears the cutter edge. After cutting all pieces to the box you attach glue in all joints and screws every 10 cm. Use more screws if the edge cutting isn't perfect.

The length of the screws should be a little more than double the board thickness. Tighten all joints with extra silicon sealing compound.

If you build a bandpass box let one side be removable to make it easier to change speaker.

Use sealing strips in the joint. The length of the screws should be 3 times the board thickness. Mount them 6 cm apart.

Use conical bass ports for best result. (DLS BP-75 or BP-110).

If the ports are too long for the box you can add a bend to it. Either cut the tube and glue it together in angle, or use factory made tube bends.

It's easier to use the factory made ones. The total length must be the same as for a straight tube. Make the measure in the center of the tube.

The port opening inside the box must not be closer to a box wall than the ports own diameter. Otherwise it will have negative effects on the airflow.

Most boxes should be damped inside with syntetic (acoustic) wool (do not use any rockwool types). Attach the damping material on the wall opposite from the speaker and port. A sealed box should be filled up to 70-100% with acoustic wool.

In a vented box the speaker and port should be mounted on the same side, otherwise a fade-out of some frequencies can occur. In most car-types, except for SEDAN cars, the speaker and port should be directed backwards for best result.

If you plan **not** to cover your box with felth cloth or imitation leather you should also tighten behind the speaker element before mounting it in the box. It must be absolutely air-tigth.

If you build an isobaric-box use through screws with nuts and washers to fasten the speakers. Also tighten the screw holes with sealing compound. Be sure to connect the isobaric speaker pair in the correct way. You can't use felt cloth or similar in front of the ports, especially in band-pass boxes.

Good luck with your box project!

BOX EXAMPLES

On the following pages you will find examples on suitable boxes for DLS speakers and subwoofers.

If you follow the advices in this handbook we are sure you achieve a good car sound.

ENCLOSURES FOR HOME USE

Very often we get questions from customers who wants to use our speakers in boxes for home use.

In general a box for home use should be 50-100% larger in volume than a box for mobile use.

Here are some suitable box volumes for some of our speakers when used for home use.

Speaker	Volume	Port / port length
226/426	25 liter	3", 1,5 cm long
PS6/PS6A	30 liter	3", 3,5 cm long
R6A	28 liter	3", 13 cm long
MS6	37 liter	3", 1,5 cm long
UP6	21 liter	3", 5,5 cm long
UR6/UR6S	20 liter	3", 15 cm long
Iridium 6	18 liter	3", 18 cm long
Iridium 8"	30 liter	3", 9 cm long

Subwoofers

OA10	33 liter	3", 21 cm long
OA12	52 liter	4", 30 cm long
W610/710	40 liter	3", 22 cm long
W612/712	60 liter	4", 34 cm long
MW10/110	40 liter	3", 23 cm long
MW12/112	62 liter	4", 33 cm long
UR10	31 liter	3", 32 cm long
UR12	41 liter	3", 22 cm long

For volumes in cubic feet, divide the volume in liter with 28,32.

For port lengths in inch, divide the port length in cm with 2,54



If you have any questions you are always welcome to contact us on DLS in Sweden. We will do our best to assist you.

E-mail: info@dls.se

ENCLOSURES FOR OLDER DLS SUBWOOFERS

SPEAKER & TYPE OF BOX:	CAR TYPE: SEDAN/SMALL	STATION WAGON	SPEAKER & TYPE OF BOX:	CAR TYPE: SEDAN/SMALL	STATION WAGON
DLS 5508: Music: Normal Vented box Port	23 liters 3" x 22 cm	26 liters 3" x 21 cm	DLS W108 / W108C: Music: Normal Vented box Port	23 liters 3" x 20 cm	26 liters 3" x 20 cm
DLS 5508A: Music: Normal Vented box Port	20 liters 3" x 22 cm	23 liters 3" x 21 cm	DLS W110 / W110C: Music: Normal Vented box Port	32 liters 3" x 14 cm	37 liters 3" x 13 cm
DLS 5310 / 5510: Music: Normal Sealed box Vented box Port, vented box	35 liters 35 liters 3" x 14 cm	41 liters 39 liters 3" x 14 cm	DLS W112 / W112C: Music: Normal Vented box Port, vented box	47 liters 4" x 23 cm	53 liters 4" x 22 cm
DLS 5310A: Music: Normal Vented box Port	37 liters 3" x 9 cm	43 liters 3" x 8 cm	DLS W110B: Music: Normal Vented box Port	35 liters 3" x 15 cm	40 liters 3" x 14 cm
DLS 5310B: Music: Normal Vented box Port	39 liters 3" x 12 cm	45 liters 3" x 11 cm	DLS W112B: Music: Normal Vented box Port	51 liters 4" x 23 cm	57 liters 4" x 22 cm
DLS 5512A: Music: Normal Vented box Port	68 liters 4" x 10 cm	78 liters 4" x 9 cm	DLS UW10: Music: Normal Vented box Port	26 liters 3" x 20 cm	29 liters 3" x 19 cm
DLS 5612: Music: Normal Vented box Port	54 liters 4" x 13 cm	63 liters 4" x 12 cm	DLS W310: Music: Normal Vented box Port	30 liters 3" x 17 cm	34 liters 3" x 17 cm
DLS 5615: Music: Normal Vented box Port	81 liters 4" x 16 cm	93 liters 4" x 15 cm	DLS W312: Music: Normal Vented box Port	47 liters 4" x 27 cm	53 liters 4" x 25 cm

ENCLOSURES FOR NEW DLS SUBWOOFERS

For the present subwoofer program we advice you to study our website www.dls.se for enclosure examples.

DLS W510C: Music: Normal Vented box Port	30 liters 3" x 22 cm	34 liters 3" x 20 cm
DLS W512C: Music: Normal Vented box Port	45 liters 4" x 21 cm	51 liters 4" x 20 cm

DLS X12:
Sealed box: 30 liters (1,06 cu ft)
Vented box: 42 liters with 29 cm(11,4") long 4" port

SOME USEFUL TABLES

TABLE 1:

Shows the relation between power increase and SPL measured 1 mtr in front of the speaker at three different speaker sensitivities.

SPL in dB

Input power (W)	1	2	3	4	5	10	15	20	50	100	200	500	1k	2k	5k	
Speaker sensitivity in dB	88	91 dB			95 dB			100 dB	105 dB	110 dB	115 dB	115 dB	120 dB	125 dB	125 dB	
	95	98 dB			102 dB			107 dB	112 dB	117 dB	122 dB	122 dB	127 dB	127 dB	127 dB	
	98	101 dB			105 dB			110 dB	115 dB	120 dB	125 dB	125 dB	130 dB	130 dB	130 dB	

A speaker with a sensitivity of 88 dB gives a SPL of 88 dB with an input of 1 Watt. If the input power is increased to 2 Watts the SPL will be 91 dB etc. Double power will increase the SPL with 3 dB.

TABLE 2:

Shows how the inner resistance (impedance) of a coil changes in relation to the frequency.

mH	Frequency in Hz																				
	25	50	75	100	120	200	400	800	1k	1,2k	2k	4k	8k	10k	12k						
0,05												1,3	2,5	3,1	3,8						
0,1												1,3	2,5	5,0	6,3	7,5					
0,2												1,3	1,5	2,5	5,0	10,0	12,6	15,1			
0,3												1,5	1,9	2,3	3,8	7,5	15,1	18,8	22,6		
0,5												1,3	2,5	3,1	3,8	6,3	12,6	25,1	31,4	37,7	
1												1,3	2,5	5,0	6,3	7,5	12,6	25,1	50,2	62,8	75,4
2												1,2	1,5	2,5	5,0	10,0	12,6	15,1	25,1	50,2	100,0
3												1,4	1,9	2,3	3,8	7,5	15,1	18,8	22,6	37,7	62,8
5												1,6	2,4	3,1	3,8	6,3	12,6	25,1	31,4	37,7	62,8
10												1,6	3,1	4,7	6,3	7,5	12,6	25,1	50,2	62,8	75,4
20												3,1	6,3	9,4	12,6	15,1	25,1	50,2			

For example a coil with 10 mH inductance, often used as lowpass filter for subwoofers, has an inner resistance (impedance) of 1,6 ohms at 25 Hz increasing to 6,3 ohms at 100 Hz, and 62,8 ohms at 1 kHz.

TABLE 3:

Shows how the inner resistance (impedance) of a capacitor changes in relation to the frequency.

μF	12 kHz	10 kHz	8 kHz	6 kHz	4 kHz	3 kHz	2 kHz	1 kHz	800 Hz	700 Hz	600 Hz	500 Hz	400 Hz	300 Hz	200 Hz	120 Hz	80 Hz	60 Hz	
0,22	60	72	90	120															
0,33	40	48	60	80	120														
0,47	28	34	42	56	85	113													
0,68	19	23	29	39	58	78	117												
1	13	16	20	27	40	53	80												
2,2	6	7	9	12	18	24	36	72	90	100	120								
3,3	4	5	6	8	12	16	24	48	60	69	80	96							
4,7	3	4	6	8	11	17	34	42	48	56	68	85							
6,8		2	3	4	6	8	12	23	29	33	39	47	58	78					
10			2	3	4	5	8	16	20	23	27	32	40	53	80				
22						2	4	7	9	10	12	15	18	24	36	60			
33							2	5	6	7	8	10	12	16	24	40	60	80	
47								3	4	5	6	7	8	11	16	28	42	56	
68									3	4	5	6	8	12	20	39	39		
100											3	4	5	8	13	19	27		
150													3	5	9	13	18		
220														2	4	6	9	12	
330															2	4	6	8	